

Product Specifications

550646 C



Temposonics RP with Captive Sliding Magnet



Temposonics RP with Floating Magnet



Temposonics RH with Standard Ring Magnet

Features

- Field programmable, digitally based smart sensor
- Direct interface to controllers
- Resolution: Selectable up to 12,500 counts per inch
- CE certified
- Modular, non-contacting design
- Field replaceable sensor cartridge (model RH only)
- 2-year warranty



PARAMETER SPECIFICATION

Measured Variable:	Displacement
Resolution:	Up to 0.002 mm/count (12500 counts/in.)
Non-Linearity:	< ± 0.01% of full stroke or ± 0.04 mm (0.0016 in.), whichever is greater*

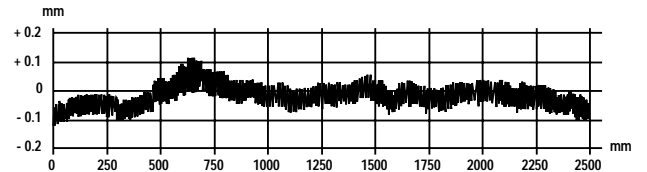

Example: Sensor Type: Temposonics RP
Measuring Range: 2500 mm
Non-linearity (measured): ± 0.116 mm

Repeatability:	< ± 0.001% of full scale or ± 0.0025 mm (0.0001 in.), whichever is greater
Hysteresis (Magnetic**):	< 0.004 mm (0.00016 in.)
Output Format:	Quadrature (A, B, Z), RS-422 differential Channels A and B are 90° out of phase
Output Frequency:	Factory programmable: 8 kHz to 1 MHz
Measuring Range:	Profile-style Sensors (RP): 25 to 5000 mm (1 to 196 in.) Rod-style Sensors (RH): 25 to 7620 mm (1 to 300 in.)
Operating Voltage:	+ 24 Vdc (+ 20%, - 15%)
Power Consumption:	100 mA typical
Operating Temperature:	Head Electronics: - 40 to 75°C (- 40 to 167°F) Sensing Element: - 40 to 105°C (- 40 to 221°F)
EMC Test:	DIN IEC 801-4, Type 4, CE Qualified; DIN EN 50081-1 (Emissions), DIN EN 50082-2 (Immunity)
Shock Rating:	100 g (single hit)/IEC standard 68-2-27 survivability
Vibration Rating:	5 g/10-150 Hz/IEC standard 68-2-6

PROFILE-STYLE (RP MODEL)

Electronic Head:	Aluminum die-cast housing
Sensor Stroke:	Aluminum profile
Sealing:	IP 65
Mounting:	Adjustable mounting feet or T-slot M5 nut in base channel
Magnet Type:	Captive sliding magnet or floating magnet

ROD-STYLE (RH MODEL)

Electronic Head:	Aluminum die-cast housing
Sensor Rod with Flange:	304L stainless steel
Operating Pressure:	350 bar static, 690 bar spike (5000 psi static; 10,000 psi spike)
Maximum Hex Torque:	45 N-m (33 ft.-lbs.)
Sealing:	IP 67
Mounting:	M18 x 1.5 or 3/4-16 UNF-3A
Magnet Type:	Ring or floating magnet

All specifications are subject to change. Please contact MTS for specifications critical to your needs.
* Varies with sensor model
** Does not include mechanical backlash on RP model magnets, style V and S magnets
For additional information, see www.mtssensors.com.

TEMPOSONICS R SERIES SENSORS WITH AQB OUTPUT

Temposonics R Series AQB position sensors produce an AB style quadrature output at a user programmable fixed pulse frequency and resolution. The absolute position information from the magnetostrictive sensor is used to generate the incremental output signals. Any change in position of the sensor magnet results in the output of an appropriate number of quadrature pulses. As is typical of quadrature signals, the sensor A and B channels lead or lag one another by 90°, (one half pulse width) depending on the direction of motion. The Z channel identifies the point where the magnet crosses the user-specified zero point.

Because all Temposonics sensors produce inherently absolute position information, the AQB sensor is capable of producing such an output if necessary. With the quadrature output signal, this is accomplished by sending a "burst" of pulses corresponding to the absolute position.

The AQB sensor can either provide this type of output at power-up after a user specified delay, or at any time during normal operation using a switched power input signal. In addition to the quadrature frequency, parameters such as leading channel select, power-up burst delay, sensor resolution (pulses/inch) and zero location are fully field programmable. This capability gives users a wider range of application for a sensor of a given stroke over conventional encoders.

Temposonics R Series sensors offer modular construction and non-contacting magnetostrictive technology. Two application housings are available: rod-style (Model RH) and profile-style (Model RP). With the RH sensors, the sensor cartridge (for sensor lengths up to 72 inches) can be quickly replaced in the field without removing the application housing (see page 4).

ADVANTAGES

- Noise immunity
- Eliminates need for external interface modules
- Cost effective data transfer
- Quadrature frequency and resolution adjustable
- Effective in measuring and positioning systems

FUNCTION

The diagram, right, illustrates the function of Temposonics R Series AQB position sensors with quadrature output. The position of a magnet mounted on a machine is precisely determined by a time-based method (i.e. magnetostriction). The sensor displacement output is incremental and quadrature pulses are only generated when magnet movement occurs. Magnet position can be determined by the system controller at any time by simply summing the total number of pulses delivered at the user-specified fixed frequency. The AQB update rate is less than 1.5 milliseconds for stroke lengths less than 100 inches.

Sensor w/AQB - Block Diagram

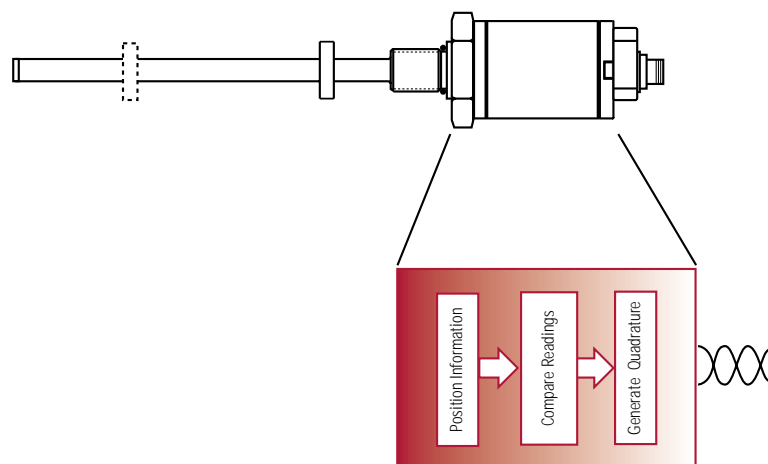

AQB INTERFACE

Quadrature is a very common means of feedback in industrial control applications. It is most often generated by encoders for both linear and rotary motion. The signal is a square-wave pulse train that is communicated at a TTL level signal (5 Vdc). As is typical of quadrature outputs, the AQB interface provides each output along with its opposite polarity format (A, \bar{A} , B, \bar{B} , Z, \bar{Z}) in order to reduce the susceptibility to external electrical noise. For encoders, resolution and pulse width are typically defined by the fixed physical characteristics of its hardware. For example, the number of physical lines per inch etched in a glass scale defines the resolution or number of pulses transmitted in a defined increment. This is usually represented in counts per inch (CPI). As the speed varies in an encoder, the width of the quadrature pulses change accordingly. Slower speeds result in longer pulse widths while higher speeds result in shorter pulse widths so that the sensor speed can be computed directly. Direction of motion is determined by which channel (A or B) leads the other by 90° (1/2 pulse width). One problem with this approach is that at very low speeds (near zero), the pulse widths will increase significantly so that updating the speed to the correct value takes longer, thus pro-

ducing a "choppy" speed output.

While similar to encoder outputs, the AQB interface differs in a number of ways. For example, the R Series AQB sensor resolution and fixed pulse frequency can be independently user-adjusted, giving this type of sensor a wider range of applicability for a given stroke range. This capability is not found in most encoders. The resolution of the AQB sensor can be varied from 50 to 12500 counts/inch (0.02 to 0.00008 inches/count). The pulse frequency has a range of 8 kHz to 1 MHz. For the highest resolution setting (0.00008 inches/count), position update times are less than 1.5 msec for stroke lengths up to 100 inches. With the AQB interface, magnet speed is not proportional to the quadrature pulse width, but can be easily computed as a function of counts (position change) per a given time interval. An important difference between the AQB interface and encoder outputs is that even the slowest speed information will be available at the user specified pulse frequency. Therefore, in some applications, the AQB interface provides a more accessible and accurate output than a typical encoder.

The Z (zero) channel is available for referencing the zero count measurement. It is traditionally used for homing, (i.e. relocating a reference posi-

tion). The AQB sensor has a multiplier to increase the width of the zero pulse. Depending on the output frequency selected the multiplier can adjust the pulse up to 15 times. The AQB sensor has two zero programming functions. The first function allows the user to simply enter in the desired location. The second, known as "teach" function, allows the user to establish the zero position by appropriately positioning the magnet and then entering the teach command.

The burst (also referred to as "send-all") mode is a feature where a continuous stream of quadrature pulses representing the absolute magnet position are sent to the controller interface. This feature should not be confused with position updating. It is intended for the controller to reestablish absolute position at critical instances. The burst mode is often used to avoid the re-homing of the system after a loss of system power. The AQB sensor can either provide this type of output at power-up after a user specified delay, or at any time ("on demand") during normal operation using a switched power input signal. The burst at start-up feature can be disabled or programmed with a delay from immediate to 30 seconds.

AQB Interface Signals

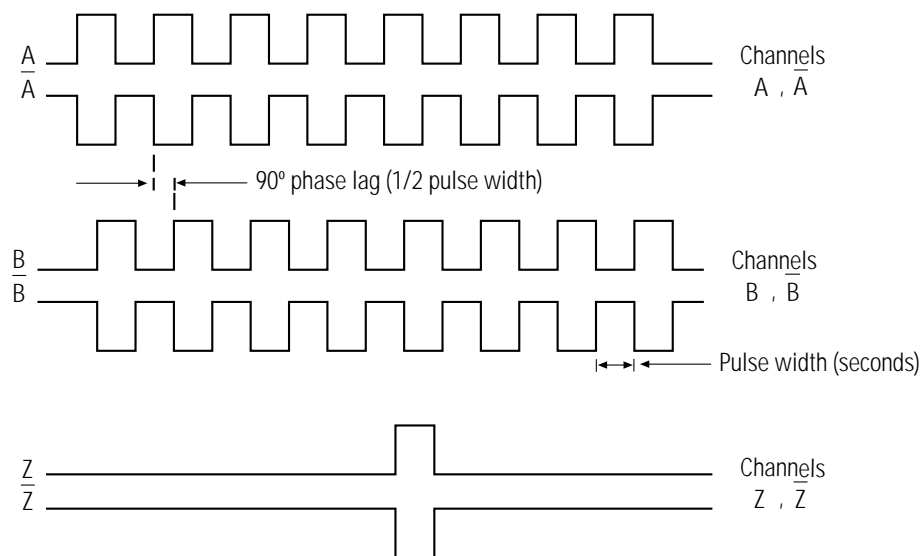

Above sample signal represents counts of sensor displacement.
 Quadrature frequency (Hz) = 1/(2 x Pulse width)

ROD-STYLE (Model RH)

The Temposonics R Series rod-style application housing (Model RH) offers modular construction, flexible mounting configurations, and easy installation. It is designed for internal mounting in applications where high-pressure conditions exist (5000 psi continuous, 10,000 psi spike) such as hydraulic cylinders. Temposonics RH may also be mounted externally in many applications.

In addition, the RH housing offers the ability to quickly and easily replace the sensor cartridge in the field (up to 72 inches).

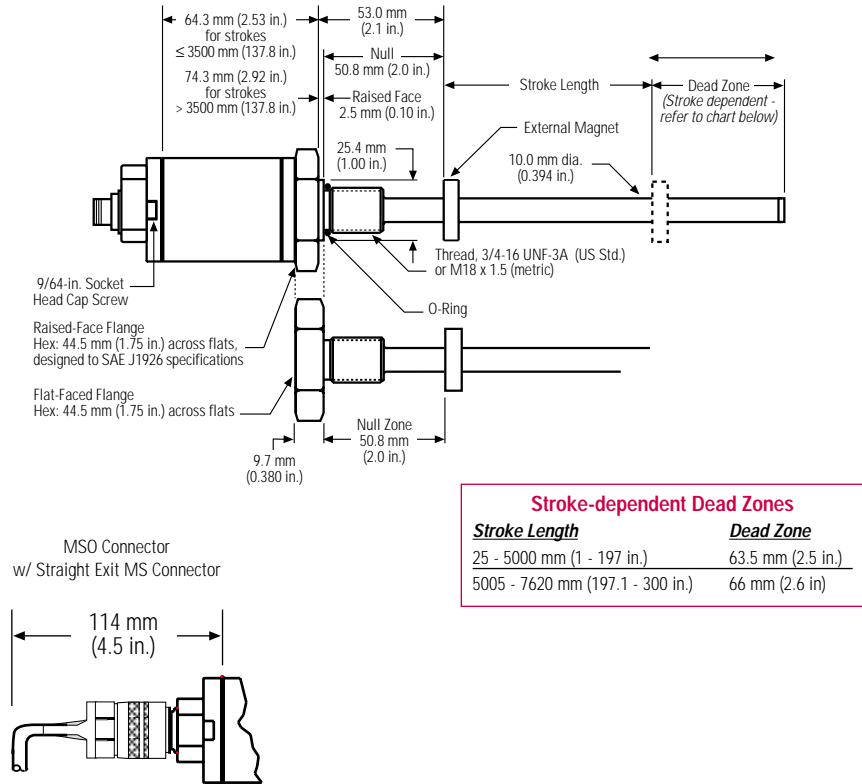

CYLINDER INSTALLATION

The rod-style Temposonics R Series position sensors (Model RH) are designed for installation into hydraulic cylinders. The sensor's high-pressure, stainless steel tube installs into a 1/2 inch bore in the piston head and rod assembly as illustrated (right).

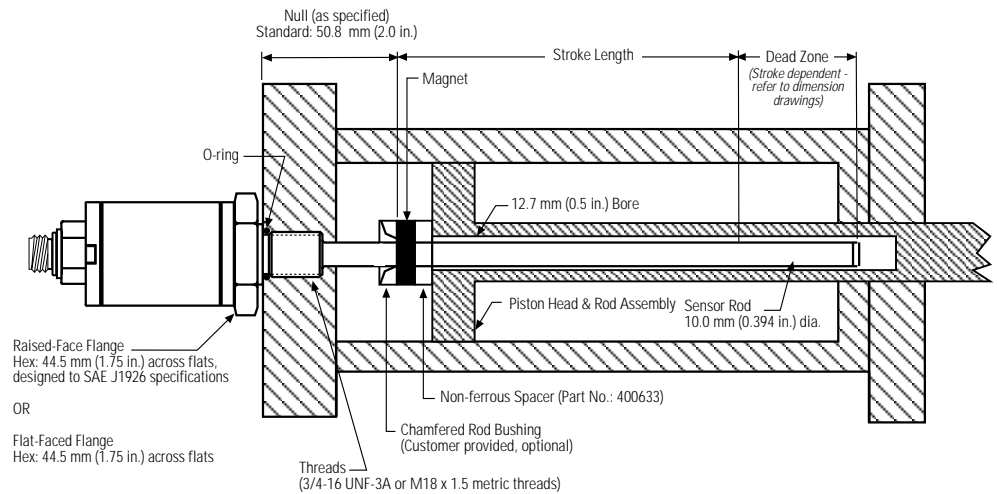

The illustration above represents a **typical** installation. Some installation requirements may be application specific.

PROFILE-STYLE (Model RP)

Temposonics RP profile-style position sensors offer modular construction, flexible mounting configurations, and easy installation. A choice of two magnet mounting configurations are available with the profile housing: captive sliding magnet or floating magnet.

Temposonics RP sensors are effective in applications where space is an issue and in environments where there are high levels of dust and conta-

mination. In addition, Temposonics RP sensors are designed for external mounting on machines and can be configured with a variety of connector options.

NOTE:

Temposonics RP Sensors include two mounting feet (Part No. 400802) for sensors up to 1250 mm (50 in.). One additional mounting foot is included for every additional 500 mm (20 in.).

CAPTIVE SLIDING MAGNET

Style V Magnet

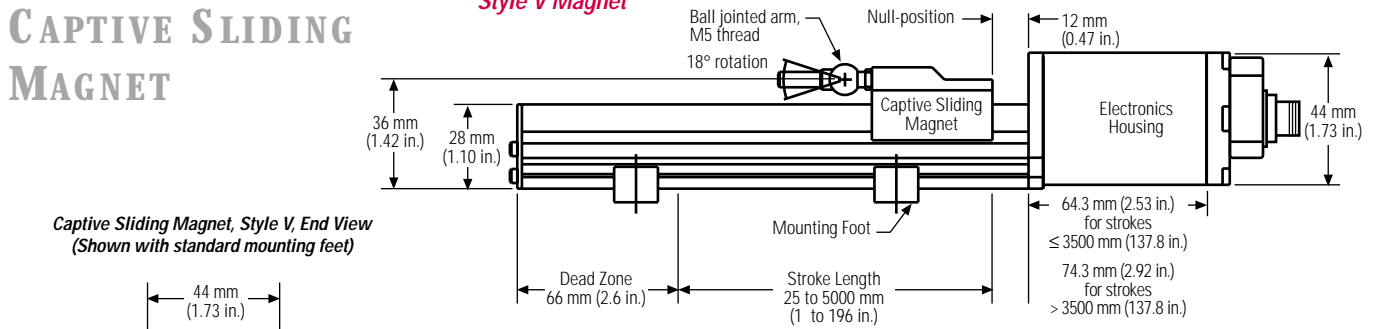

Style S Magnet

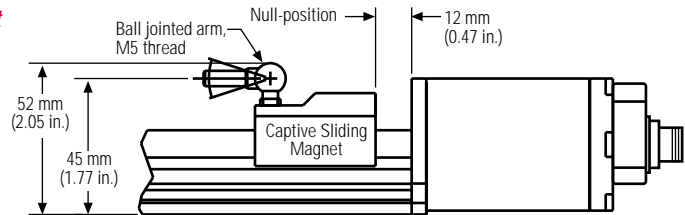

FLOATING MAGNET

Style M Magnet

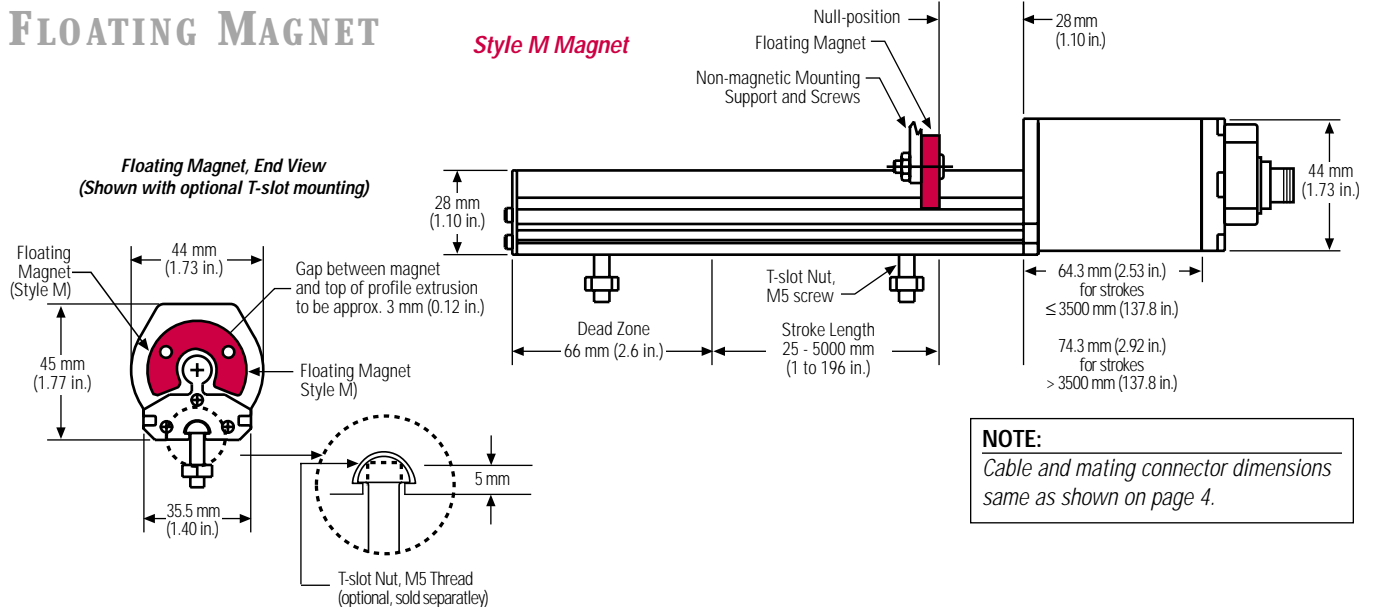

NOTE:

Cable and mating connector dimensions same as shown on page 4.

SENSOR INTEGRAL CONNECTOR (MSO Male)

Pin No.	Wire Color	Function
A	Blue	Programming
B	Brown	Programming / Burst Input
C	Gray	A+
D	Pink	A-
E	Red	+ 24 Vdc, Customer Supplied
F	White	DC Ground
G	Black	B+
H	Purple	B-
J	Yellow	Z+
K	Green	Z-

MSO Connector
(As viewed from end of sensor)

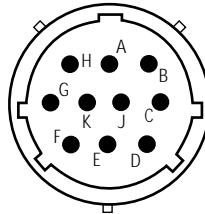

NOTE:

RS-232 Connections to personal computer for programming output parameters is as follows, (requires optional CD ROM Software, Part No. 550844).

AQB Sensor Pin No.	PC's DB9 COM port Pin. No.	COM Port Settings
A Programming TX	2 RX	Baud: 9600
B Programming RX	3 TX	Data bits: 8
F DC Ground	5 Ground	Parity: None
		Stop bits: 1
		Flow control: None

Sensor must be powered for programming.

CABLE CONNECTOR (Field-installable MS Female)

Part No. 370013

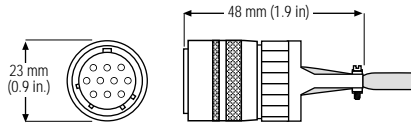

NOTE:

Appropriate grounding of cable shield is required at the controller end.

MAGNETS

Magnets must be ordered separately with Temposonics RH sensors. The standard ring magnet (Part No. 201542) is suitable for most applications.

Magnets are included with the order of Temposonics RP sensors. Temposonics RP can be configured with one of two magnet configurations: captive sliding magnet or floating magnet. There are two styles of captive sliding magnets, and one style of floating magnet.

Captive Sliding Magnet, Style V
Part No. 252111-1

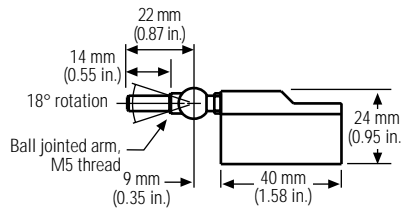

Captive Sliding Magnet, Style S
Part No. 252110-1

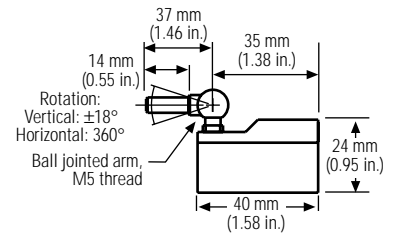

Floating Magnet
(May be used with Temposonics RH and RP)
Part No. 251416

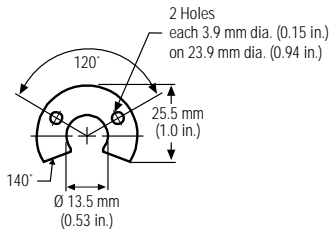

ID: 13.5 mm (0.53 in.)
OD: 32.8 mm (1.29 in.)
Thickness: 7.9 mm (0.312 in.)

Standard Ring Magnet
Part No. 201542

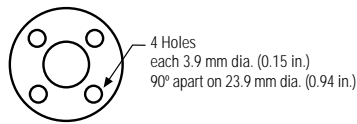

ID: 13.5 mm (0.53 in.)
OD: 32.8 mm (1.29 in.)
Thickness: 7.9 mm (0.312 in.)

Magnet Spacer
Part No. 400633

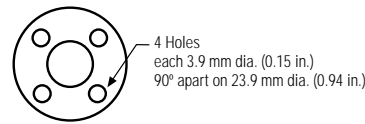

ID: 14.3 mm (0.56 in.)
OD: 31.8 mm (1.25 in.)
Thickness: 3.2 mm (0.125 in.)

Ring Magnet
Part No. 400533

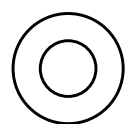

ID: 13.5 mm (0.53 in.)
OD: 25.4 mm (1.0 in.)
Thickness: 7.9 mm (0.312 in.)
(For use with strokes ≤ 3050 mm or 120 in.)

ACCESSORIES

Description	Part No.	Notes
O-Ring (spare)	560315	For use with Temposonics RH sensors
Hex Jam-nut (w/ 3/4-16 UNF threads)	500015	For use with Temposonics RH sensors
Hex Jam-nut (w/ M18x 1.5 threads)	500018	For use with Temposonics RH sensors
Magnet Spacer	400633	For use with Standard Ring Magnet Part No. 201542
Magnet Mounting Screws	560357	Used to mount Standard Ring Magnet Part No. 201542 (4 screws) and 90° Cut-out Magnet Part No. 201552 (2 screws)
140° Cut-out Floating Magnet	251416	Spare for Temposonics RP sensors
Captive Sliding Magnet, Style V	252111-1	Spare for Temposonics RP sensors, Rod joint at front of magnet
Captive Sliding Magnet, Style S	252110-1	Spare for Temposonics RP sensors, Rod joint at top of magnet
Joint Rod Sleeve	401603	Optional accessory for Temposonics RP sensors
Ball jointed arm	401913	Optional accessory for Temposonics RP sensors
Power Supply (24/28 Vdc, 0.5 A)	380009	
Mounting Feet, Standard (spares for RP sensors)	400802	Temposonics RP position sensors are provided with a set of Mounting Feet
Mounting Feet, Low-profile	400867	
T-slot M5 Nut	401602	Optional accessory for mounting Temposonics RP sensors
Cable (5 twisted pairs, shielded)	530021	Specify length in feet at time of order
MS Field-installable Connector	370013	Female, straight exit, mates to MSO connection type
CD ROM	550844	Optional software for programming output parameters

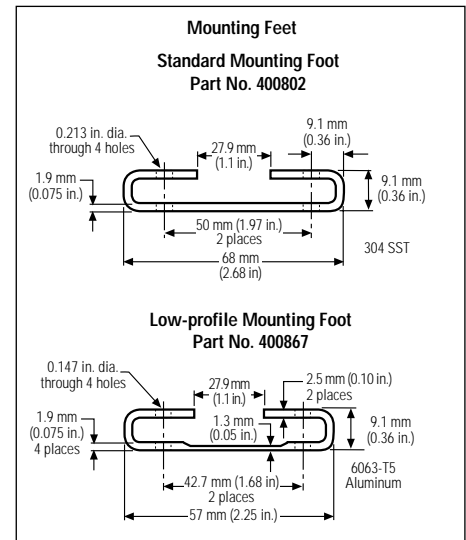
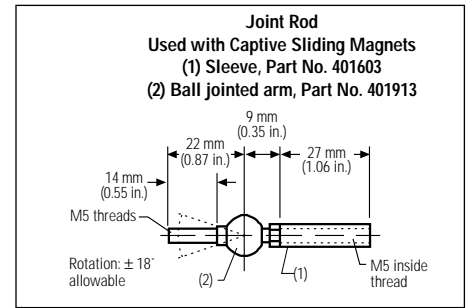

OPTIONAL EXTENSION RODS (for use with Captive Sliding Magnet)

Description	Part No.	Description	Part No.
2 in. Extension Rod	401768-2	15 in. Extension Rod	401768-15
3 in. Extension Rod	401768-3	18 in. Extension Rod	401768-18
4 in. Extension Rod	401768-4	20 in. Extension Rod	401768-20
6 in. Extension Rod	401768-6	21 in. Extension Rod	401768-21
7 in. Extension Rod	401768-7	24 in. Extension Rod	401768-24
8 in. Extension Rod	401768-8	30 in. Extension Rod	401768-30
9 in. Extension Rod	401768-9	36 in. Extension Rod	401768-36
10 in. Extension Rod	401768-10	42 in. Extension Rod	401768-42
12 in. Extension Rod	401768-12	48 in. Extension Rod	401768-48
14 in. Extension Rod	401768-14	60 in. Extension Rod	401768-60

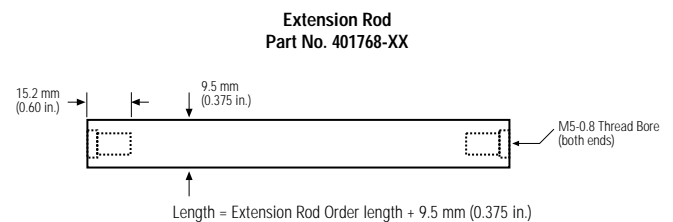

SENSORS
GROUP

Pioneers,
Innovators,
Leaders in
Magnetostrictive
Sensing

UNITED STATES
MTS Systems Corporation
Sensors Division
3001 Sheldon Drive
Cary, NC 27513
Tel: 800.633.7609
Fax: 919.677.0200
Web: www.mtssensors.com
Email:
displacement@mtssensors.com

GERMANY
MTS Systems Corporation
Sensors Technologie
Auf dem Schuffel 9, D-58513 Lüdenscheid, Germany
Postfach 8130 D-58489 Lüdenscheid, Germany
Tel: + 49.2351.95870
Fax: + 49.2351.56491
Web: www.mtssensor.de

JAPAN
MTS Systems Corporation
Sensors Technologie Japan
Ushikubo Bldg.
737 Aihara-cho, Machida-shi
Tokyo 194-0211, Japan
Tel: + 81 (42) 775.3838
Fax: + 81 (42) 775.5512

