

Product Specifications

FEATURES

- 2-year warranty
- Modular, non-contacting design
- Excellent resolution and repeatability
- Analog outputs (Voltage or Current)
- Digital output (Start/Stop or PWM)
- Easy to install
- Shock and vibration resistant
- Mounting flexibility
- Drip, dust, rust resistant
- 24-hour emergency technical support
- CE Certified (Model dependent)

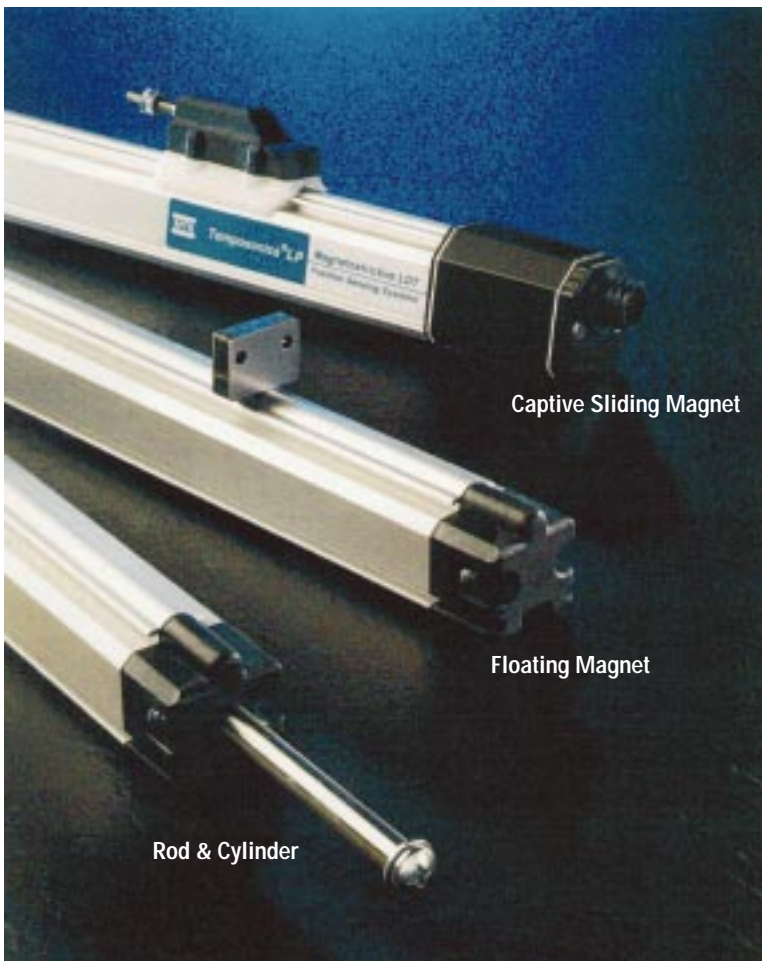

Temposonics® L Series LP profile-style position sensors are available with analog outputs (voltage or current) or digital outputs (Start/Stop or PWM). All outputs are absolute rather than incremental so that power-down situations do not require re-homing.

Mechanically, the LP sensors mount and function similar to linear potentiometers and LVDTs, however, they offer several advantages: high precision, increased durability, and cost effectiveness. In addition, Temposonics LP position sensors use non-contacting magnetostrictive technology.

Three easy-to-install magnet configurations are available to meet your specific application requirements: floating magnet, captive sliding magnet, and rod & cylinder. Stroke lengths are available up to 144 inches, output dependent. (Note: rod & cylinder versions are limited to a maximum stroke length of 48 inches.)

PARAMETER	SPECIFICATION
Measured Variable:	Displacement
Resolution:	<i>Analog:</i> Infinite <i>Digital:</i> 1 ÷ [gradient x crystal freq. (mHz) x circulation]; maximum resolution: 0.006 mm or 0.00025 in.
Non-Linearity*:	<i>Captive Slide:</i> ± 0.02% or ± 0.127 mm (0.005 in), whichever is greater <i>Rod & Cylinder and Floating Magnet:</i> ± 0.02% or ± 0.152 mm (0.006 in), whichever is greater
Repeatability:	Equal to resolution
Hysteresis:	< 0.02 mm (0.0008 inches)
Outputs:	<i>Analog:</i> Voltage or Current <i>Digital:</i> Start/Stop or PWM
Measuring Range:	<i>Analog:</i> 25 to 2000 mm (1 to 78 in.) <i>Digital:</i> 25 to 3650 mm (1 to 144 in.) [Rod & Cylinder version: max length = 1220 mm (48 in.)]
Operating Voltage:	+ 13.5 to 26.4 Vdc (± 0%): Strokes ≤ 1525 mm (60 in.) + 24 Vdc (± 10%): Strokes > 1525 mm (60 in.)
Power Consumption:	100 mA
Operating Temperature:	<i>Head Electronics:</i> - 40 to 85°C (- 40 to 185°F) <i>Sensing Element:</i> - 40 to 105°C (- 40 to 221°F)
EMC Test:	DIN IEC 801-4, Type 4, CE Qualified; DIN EN 50081-1 (<i>'G'</i> style connector only) (Emissions), DIN EN 50082-2 (Immunity)
Shock Rating:	100 g (single hit)/IEC standard 68-2-27 (survivability)
Vibration Rating:	5 g/10-150 Hz/IEC standard 68-2-6
Update Time:	<i>Analog:</i> < 1 ms <i>Digital:</i> Minimum = [Stroke (specified in inches) + 3] x 9.1 µs
Housing Style/Enclosure:	Aluminum profile; drip, dust, and rust resistant 'G' style connection meets IP 67 rating
Magnet Type:	Floating magnet, captive sliding magnet, rod & cylinder

* Non-linearity increases with multiple circulations.

The above specifications are assuming that output ripple is averaged by the measuring device as with any typical analog device. Specifications are subject to change without notice. Contact MTS to confirm specifications that are critical to your application.

OUTPUTS

ANALOG & DIGITAL OUTPUTS

The Temposonics L Series LP position sensors provide direct analog or digital outputs.

Analogue outputs include: voltage (0 to 10 Vdc; forward & reverse acting) and current (4 - 20 mA or 0 - 20 mA, forward or reverse acting).

If a digital format is required, Start/Stop or Pulse-width Modulated

(PWM) outputs are also available. The Start/Stop output requires a customer-supplied 1µs interrogation signal.

Since both the analog and digital outputs are direct, no signal-conditioning electronics are needed when interfacing with controllers or meters.

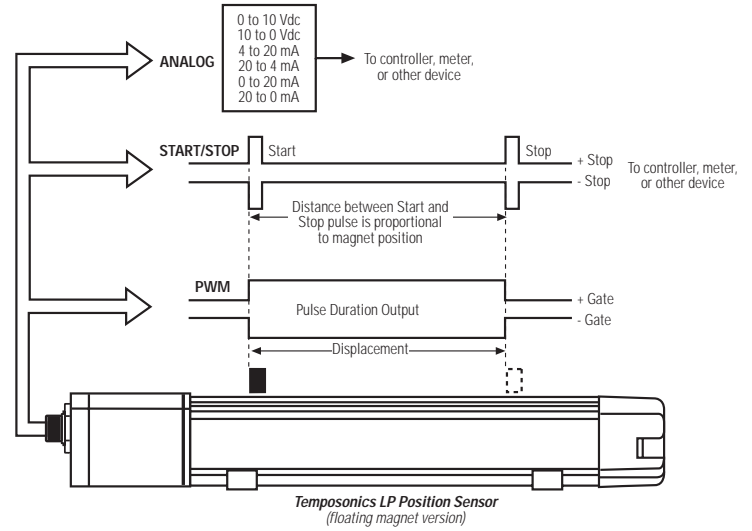

FEATURES

- Outputs Include:
 - Start/Stop
 - Pulse-width modulated (PWM)
 - Voltage
 - Current
- Rugged Construction
- Direct Outputs—No Signal-conditioning Required
- High Resolution
- Drip, Dust, Rust Resistant

MAGNET CONFIGURATIONS

Floating Magnet

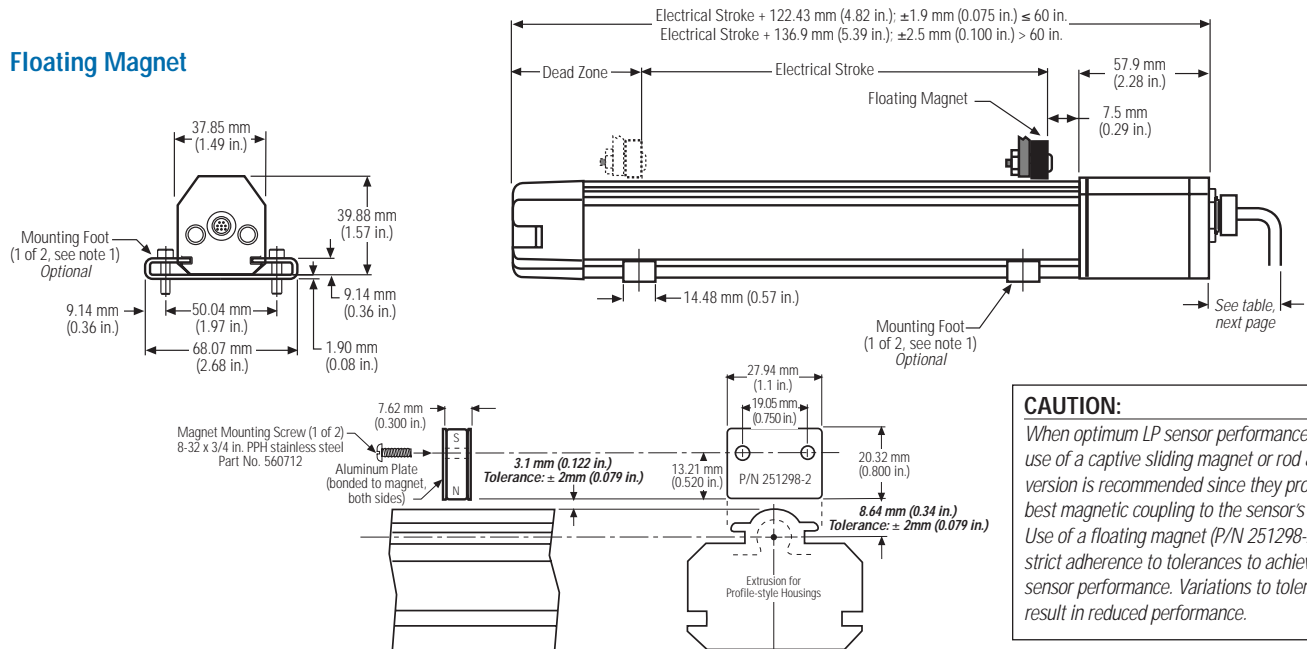

DIMENSIONS

MAGNET CONFIGURATIONS

Temposonics LP profile-style position sensors offer modular construction, flexible mounting configurations, and easy installation. There are three magnet configurations offered to meet the mounting requirements of your application: (1) floating magnet, (2) captive sliding magnet, and (3) rod and cylinder (refer to the illustrations, below).

Temposonics LP sensors are effective in applications where space is an issue and in environments where there are dust and contamination. They are designed for external mounting on machines and can be configured with a variety of connection options.

Captive Sliding Magnet

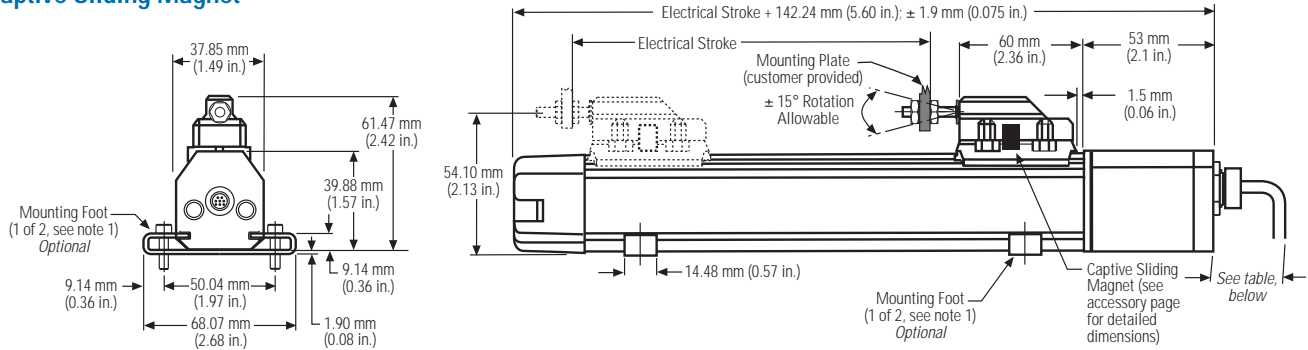

Rod & Cylinder

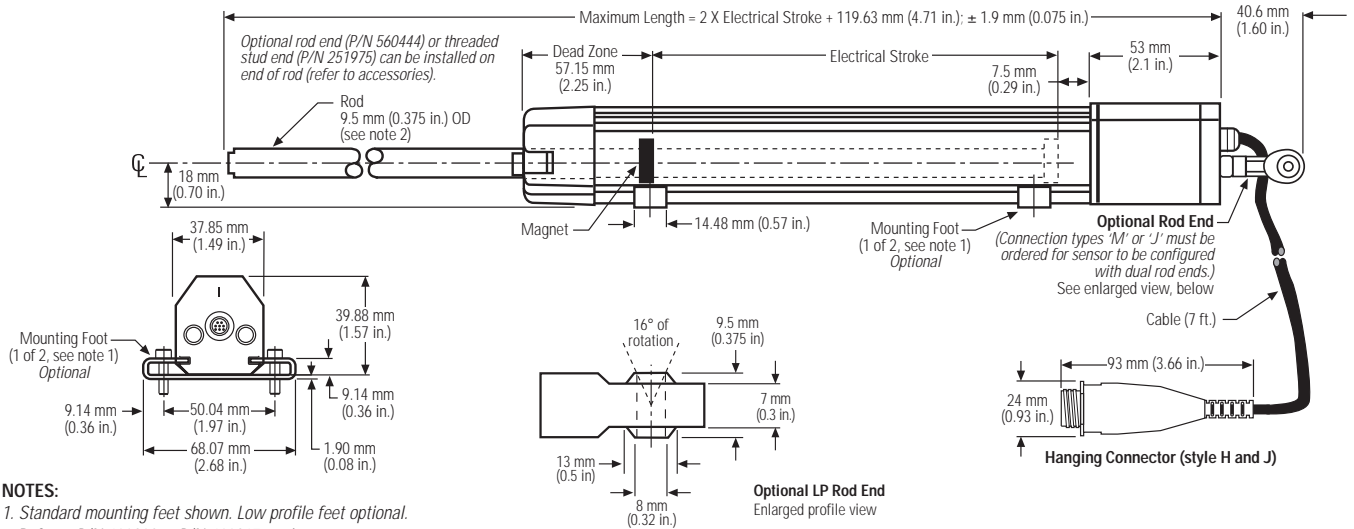

NOTES:

- Standard mounting feet shown. Low profile feet optional. Refer to P/N 400802 or P/N 400867 on the accessory page for detailed dimensional information.
- Proper mounting and alignment of sensor is critical to ensure normal operation.

CONNECTOR DIMENSIONS (includes cable bend)

- 'G' Connector w/ Straight Exit 'RG' Mating Connector: 61 mm (2.4 in.)
- 'G' Connector w/90° 'RA' Mating Connector: 34 mm (1.35 in.)
- 'C' Integral Connector w/Mating Connector: 114.3 mm (4.5 in.)
- 'H', 'J', 'L', and 'M' Integral Cables: 20 mm (0.8 in.)

WIRING

CONNECTIONS

Analog Output: Voltage Output:

Pin No.	Wire Color	Function
1	Blue	0 to 10 Vdc (Note 1)
2	Green	Return for Pin 1
3	Yellow	10 to 0 Vdc (Note 2)
4	Orange	Return for Pin 3
5	Red	Customer Supplied Power (+ Vdc)*
6	Black	DC Ground
7	Drain Wire	Shield Drain Wire (Note 3)
8	N/C	N/C

Analog Output: Current Output:

Pin No.	Wire Color	Function
1	Blue	4 to 20 mA, 0 to 20 mA
2	Green	20 to 4 mA, or 20 to 0 mA
3	Yellow	Return for Pin 1
4	Orange	N/C
5	Red	Customer Supplied Power (+ Vdc)*
6	Black	DC Ground
7	Drain Wire	Shield Drain Wire (Note 3)
8	N/C	N/C

Digital Output: (PWM or Start/Stop)

Pin No.	Wire Color	Function (PWM)
1	Blue	(-) Gate for PWM, (-) Stop for Start/Stop
2	Green	(+) Gate for PWM, (+) Stop for Start/Stop
3	Yellow	(-) Interrogation for PWM, (-) Start for Start/Stop
4	Orange	(+) Interrogation for PWM, (+) Start for Start/Stop
5	Red	Customer Supplied Power (+ Vdc)*
6	Black	DC Ground
7	Drain Wire	Shield Drain Wire (Note 3)
8	N/C	N/C

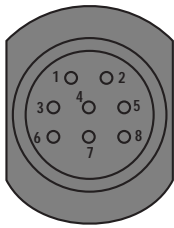

8-Pin Integral or Hanging Connector (male profile)
Connection Type 'C', 'H', or 'J'
Mating Accessories:
 • P/N 251135 Field Installable Connector
 • Extension Cables

* Power requirements are stroke length dependent.
 + 13.5 to 26.4 Vdc ($\pm 0\%$): Stroke lengths ≤ 1525 mm (60 in.)
 + 24 Vdc ($\pm 10\%$): Stroke lengths > 1525 mm (60 in.)

NOTES:

1. Output = 0 Vdc when reference magnet is positioned at the electronics housing end of the sensor.
2. Output = 0 Vdc when reference magnet is positioned at the tip of the sensor.
3. Shield drain wire should be isolated from DC ground (black wire) at the controller end of the cable.

CONNECTIONS FOR 'G' STYLE MATING CABLES

RG Connector: (PWM or Start/Stop)

Pin No.	Wire Color	Function
1	Gray	(-) Gate for PWM, (-) Stop for Start/Stop
2	Pink	(+) Gate for PWM, (+) Stop for Start/Stop
3	Yellow	(+) Interrogation for PWM, (+) Start for Start/Stop
4	Green	(-) Interrogation for PWM, (-) Start for Start/Stop
5	Red or Brown	Customer Supplied Power (+ Vdc)*
6	White	DC Ground
7	-	No Connection

RG Connector: (Voltage or Current Output)

Pin No.	Wire Color	Function
1	Gray	0 to 10 Vdc 4 to 20 mA or 0 to 20 mA
2	Pink	Return for Pin 1
3	Yellow	10 to 0 Vdc 20 to 4 mA or 20 to 0 mA
4	Green	Return for Pin 3
5	Red or Brown	Customer Supplied Power (+ Vdc)*
6	White	DC Ground
7	-	No Connection

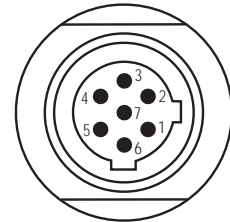

**'G' Connector
(Molded Mating)**
Extension Cable Required)

NOTES:

1. When wiring Tempsonics L Series LP sensors equipped with a 'G' style connector, **do not connect DC ground to the cable shield or drain wire.**
- 2.) For single-ended interrogation, the unused interrogation lead must be connected to DC ground.
- 3.) When using PWM with internal interrogation, both interrogation leads must be connected to DC ground.

* Power requirements are stroke length dependent.
 + 13.5 to 26.4 Vdc ($\pm 0\%$): Stroke lengths ≤ 1525 mm (60 in.)
 + 24 Vdc ($\pm 10\%$): Stroke lengths > 1525 mm (60 in.)

TYPICAL 4-20 mA WIRING:

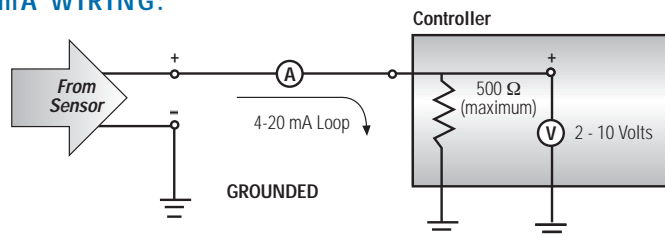

NOTE:
 Minimum load impedance for voltage outputs is 5K Ω .

POSITION SENSOR

When placing an order, build the desired model number using the model number guide (right). A selection of Temposonics LP sensor configurations are available to meet the demands of your particular application.

If you have any questions about how to apply MTS Temposonics position sensors, please contact one of our Application Engineers or your local distributor—they are available to help you design an effective position sensing system to fit your application.

Stroke Length Limitations:

Sensors with analog output: 78 in. (2000 mm).
Sensors with digital output: 144 in. (3650 mm).
Rod & Cylinder sensors: 48 in. (1225 mm).



- SENSOR MODEL** _____
LP = Profile Style Sensor (mounting feet included, Note 1)
- MAGNET CONFIGURATION** _____
S = Captive Sliding Magnet (Note 3)
 (provided with #10-32 threads when stroke length is defined in inches;
 provided with M5 threads when stroke length is defined in millimeters)
D = Captive Sliding Magnet (for Die Cast)
 Additional rod end (P/N 560444) is required, order separately
Consult Applications Engineering before ordering.
M = Floating Magnet (P/N 251298-2, included with sensor) (Note 3)
R = Rod & Cylinder (Note 3)
- CONNECTION TYPE** _____
C = Integral Connector (mating connector ordered separately)
G = 7-pin Micro connector (CE approved)
L = Cable (7 ft.) with pigtail connection
M = Cable (7 ft.) with pigtail connection; configured for dual rod ends,
 kit included - P/N 251411
H = Cable (7 ft.) with attached connector
J = Cable (7 ft.) with attached connector; configured for dual rod ends,
 kit included - P/N 251411
- OUTPUT** _____
S = Start/Stop
P = Pulse-width Modulated (See 'PWM Output' for options, below)
V = Voltage (0 to +10 Vdc or +10 to 0 Vdc)
A = 4 to 20 mA
B = 20 to 4 mA
C = 0 to 20 mA
D = 20 to 0 mA
- UNIT OF MEASURE** _____
U = US customary (inches and tenths: xxx.x in.)
M = Metric (millimeters: xxxx mm)
- LENGTH** (see Notes 2 & 3) _____
 ____ . ____ = Inches and tenths (Encode length in 1.0 in. increments)
 or
 _____ millimeters (Encode length in 5 mm increments)
- INPUT VOLTAGE** _____
1 = +13.5 to 26.4 Vdc ($\pm 0\%$) for strokes ≤ 60 inches
2 = +24 Vdc ($\pm 10\%$) for strokes > 60 inches
- PWM OUTPUT** _____

Complete the following only if Output style 'P' is selected, above
00 $\frac{\text{a}}{\text{b}}$ $\frac{\text{c}}{\text{c}}$ = PWM Output (Fill in the three blanks with the following codes)

- a) Interrogation** **b, c) Circulations**
E = External _____ = desired number of circulations (see tables A and B)
I = Internal

Table A

Circulation Count vs. Resolution for PWM Output (Based on 28 MHz counter)

Resolution	Circulation Count*
0.00026	15
0.0005	8
0.001	4
0.002	2
0.004	1

* Maximum circulation count is limited by stroke length for sensors configured for internal interrogation. (Refer to Table B for stroke length limitations.)

Table B

Maximum Stroke per Circulation Count for PWM Output w/Internal Interrogation

Maximum Stroke	Circulation Count
≤ 84 inches	15
> 84.1 inches	1

NOTES:

- Standard mounting feet (P/N 400802) are included with Temposonics LP sensors with connection types C, L, or H (not provided with connection types M or J).
- Standard Temposonics LP stroke lengths: 3, 6, 9, 12, 15, 18, 21, 24, 30, 36, 42, 48 inches.
- Non-standard lengths are available in 1 inch increments up to 144 inches (analog units are limited to 78 inches) except for rod and cylinder versions which are limited to a maximum stroke length of 48 inches (1225 mm). Additional lead time may be required for non-standard lengths.
- Standard extension cable lengths available.

RETROFIT NOTE:

Please consult an MTS applications engineer before retrofitting an original Temposonics LP that is being used with a Temposonics accessory product such as an AOM, TDU100, MK292, etc.

EXTENSION CABLES

Connector Types 'C', 'H', & 'J' Mating Extension Cables



CABLE LENGTH _____

- 005 = 5 ft.
- 015 = 15 ft.
- 025 = 25 ft.
- XXX = Custom length (range: 5 to 100 ft.)

NOTE:

Extension cables terminate with a pigtail connection.

Connector Type 'G' Mating Extension Cables



SENSORS CONNECTION TYPE _____

- RG = Mating Connector for Style "G" sensor only (straight)
- RA = Mating Connector for Style "G" sensor only (90°)

CABLE LENGTHS _____

- 005 = 5 ft.
- 015 = 15 ft.
- 025 = 25 ft.
- 050 = 50 ft.
- 100 = 100 ft.

CABLE TERMINATION _____

- P0 = Pigtail connection

NOTE:

Extension cable terminates with a pigtail connection.

ACCESSORIES

Description	Part No.	Notes
LP Magnet Assembly (spare)	251298-2	Spare for Temposonics LP position sensors with floating magnet
Mounting Screws (8/32 x 3/4 in. Stainless Steel)	560712	Spare for mounting floating magnet assembly, P/N 251298-2, for use with Magnet Configuration 'M'.
Captive Sliding Magnet, US version (spare)	252052	Spare for Temposonics LP position sensors with electrical strokes defined in inches (#10-32 threads). See drawing, below
Captive Sliding Magnet, Metric version (spare)	252053	Spare for Temposonics LP position sensors with electrical strokes defined in millimeters (M5 threads). See drawing, below
Power Supply (24/28 Vdc, 0.5 A)	380009	
Mounting Feet, Standard (spare)	400802	See drawing, below
Mounting Feet, Low Profile (optional)	400867	See drawing, below
Rod End	560444	For use with Temposonics LP sensors with Connection Types 'M' or 'J' (rod & cylinder versions) to provide a means to attach the LP rod to customer equipment, See drawing, below
Threaded Stud End Kit	251975	For use with Temposonics LP sensors (rod & cylinder versions) to provide a means to attach the LP rod to customer equipment. Includes threaded stud with stationary jamb nut, two (2) hex nuts and a washer. See drawing, below
Field-Installable Receptacle Connector Kit	251135	Mating connector for Temposonics LP sensor with connection types 'C', 'H', or 'J'.

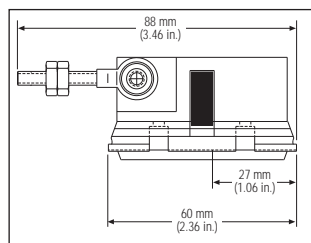
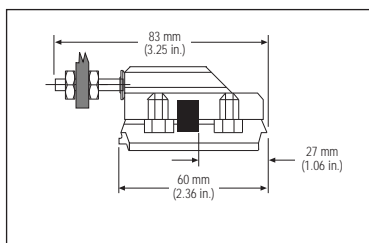
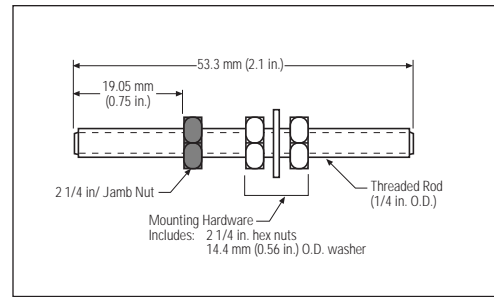
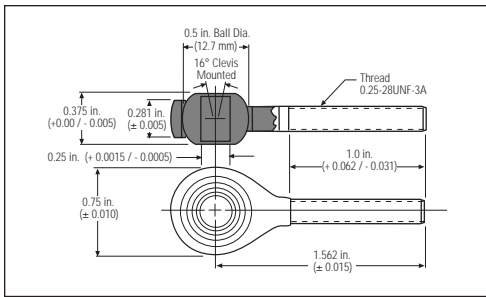
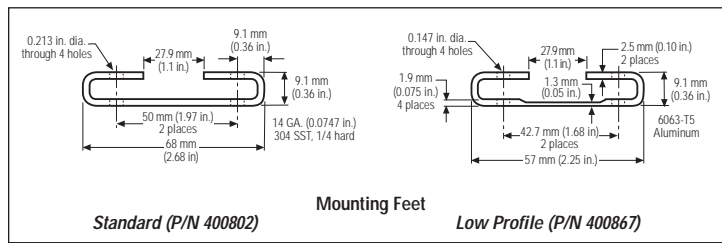



SENSORS
G R O U P

Pioneers,
Innovators,
Leaders in
Magnetostrictive
Sensing

UNITED STATES
Sensors Division
3001 Sheldon Drive
Cary, NC 27513
Phone: 800-633-7609
Fax: 919-677-0200
Internet: www.temposonics.com

GERMANY
Auf dem Schuffel 9, D-58513 Lüdenscheid, Germany
Postfach 8130 D-58489 Lüdenscheid, Germany
Phone: + 49-2351-95870
Fax: + 49-2351-56491

JAPAN
Ushikubo Bldg.
737 Aihara-cho
Machida-shi
Tokyo 194-0211
Japan
Phone: + 81 (42) 775-3838
Fax: + 81 (42) 775-5512

